



SELECT SERIES PRODUCT SHEET

HR 100 Tandem Ladder

CHASSIS

- E-ONE Cyclone or Typhoon Cab
- Cab Lengths:
 - Medium (58")
 - Long (67.5")
- GAWR: 22,800# Front Axle, 48,000# Rear Axle
- Wheelbase
 - 230" W/ Medium Cab
 - 240" W/ Long Cab
- Spring or Air Ride Suspension
- Flat or 12" Split Raised Roof
- Barrier Style or Extended Cab Doors
- Seating Packages for up to 6 from Valor, Bostrom and 911 (SCBA or non-SCBA)
- Interior Storage Cabinets Over Wheels or Center Rear Wall
- HD Channel Style Bumper 20" with Center Tray or 28" with Double Crosslays
- Dimensions:
 - OAH: 11'-7" +/- 1"
 - OAL: 40'-10" to 42'-2" +/- 1"
 - Depending Upon Options

BODY FEATURES

- Extruded Aluminum Body
- SideStacker™ Hose Bed
- Extended Height L1 / L2 / L3 and R1 / R2 Compartments
- Hinged or Combo of Hinged and Roll-up; ROM or Amdor; Satin or Painted
- Angled Rear Body Corners Optional
- Storage for Alco-Lite or Duo-Safety Ladders
- Hosebed Capacity: 900 - 1000' 5" LDH + 300 - 400' 2.5/3" DJ

ELECTRIC & WARNING

- Various Models of Whelen or Federal Warning Lights
- Optional Rear Directional Bar
- Whelen or Federal Electronic Siren, Q2B Optional
- Whelen, FireTech or Federal Scene Lighting Packages
- Optional 8kW Generator with Cord Reel, Side Receptacles and Tip Receptacle
- Whelen or FireTech Aerial Tip / Base Lighting
- Optional Amdor Climbing Lights

AERIAL

- Welded Aluminum Construction
- 2.5 to 1 Structural Safety Factor
- 500# Tip Load (Wet or Dry)
- Reach: 100' Vertical; 92' Horizontal
- Advanced Aerial Controls; Tip Controls Optional
- (4) Crisscross Underslung Jacks with 12' Spread
- Aerial Equipment Options Include Lifting Eyes, Roof Ladder Brackets, Axe, Pike Pole, Rope Roller, Stokes Basket.

PUMP & PLUMBING

- Hale Qmax 1500 or 2000 GPM (6000 LPM optional); Waterous CSU 1500 or 2000 GPM (6000 LPM optional)
- 500 Gallon Water or 480 Water / 20 Gallon Foam Tank
- FoamPro 2002 or Foam Manifold Package
- Pump Module with Triple Crosslays with (2) 1.75" and (1) 2.5" or Double with (1) 1.75" and (1) 2.5". Dunnage Pan Standard, Backboard Storage Optional.
- Akron StreamMaster II or TFT Flex (Pinnable Standard). 2.5" Valve and Extended Range Optional



E-ONE
OCALA FL
PRELIMINARY DRAWING
AERIAL BODY W/ SIDE STACKER HOSEBED
E-ONE TYPHOON CHASSIS
HR100 LADDER

THIS DRAWING IS FOR REFERENCE PURPOSES. ALL DIMENSIONS ARE SUBJECT TO MINOR VARIATIONS DUE TO MANUFACTURING PROCESSES.

This print is the property of E-One, Inc. and is loaned to you subject to return on demand, unless otherwise agreed to in writing by E-One, Inc. It contains one confidential and must not be copied or transmitted to third parties for sale or distribution.

HOSE LOAD:			
2000 GPM HALE QMAX PUMP			
480 GALLON WATER TANK			
20 GALLON CLASS A FOAM			
HOSE COMPLIANT			
COMP. #	INTERIOR DIMENSION		
L1/R1	31W 59H 21W 30H 17D UPPER LOWER		
L2/R2	28W 69H 21W 38H 14D UPPER LOWER		
L3	50W 35H 50W 28H 24D UPPER LOWER		
R3	31W 19H 31W 19H 14D		
L4	63W 23H 63W 23H NOTED		
R4	49W 26H 49W 26H 2.3D		
L5	60W 46H 60W 17H 23D 65W 28H NOTED UPPER LOWER		
GROUND LADDERS			
ITEM	LADDER LENGTH	MODEL NUMBER	QTY
A	35' 2-SECT.	1200-A 35'	1
B	28' 2-SECT.	1200-A 28'	1
C	24' 2-SECT.	900-A 24'	1
D	14' ROOF	775-A 14'	2
E	16' ROOF	775-A 16'	1
F	10' FOLDING	585-A 10'	1
G	LITTLE GIANT	MODEL 17	1

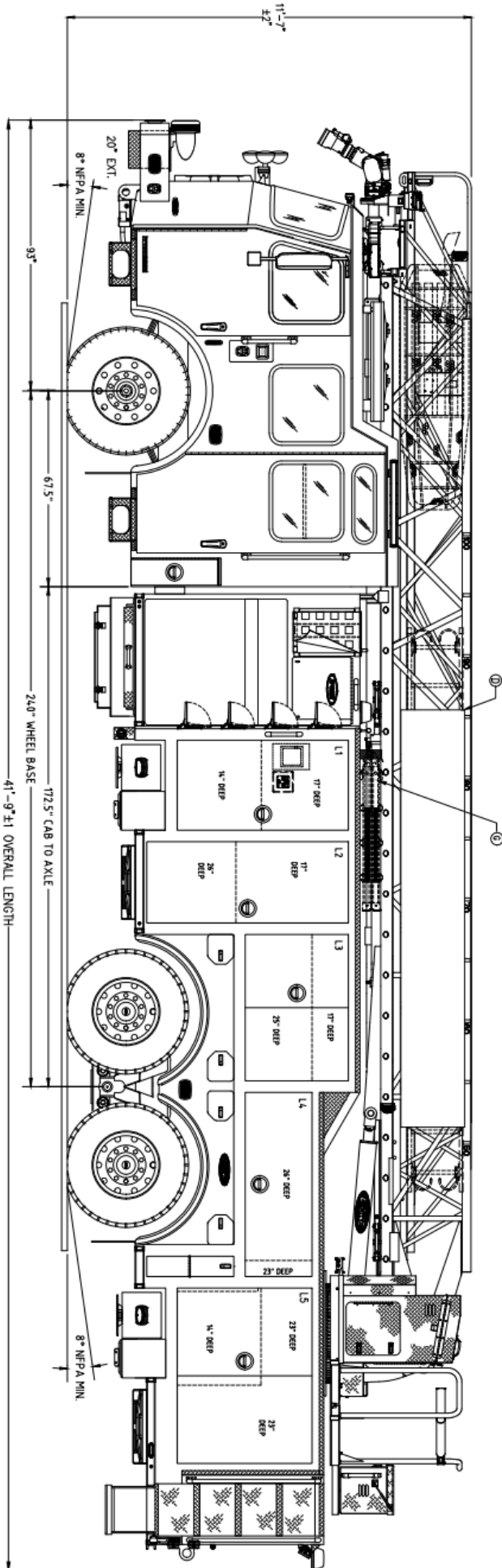
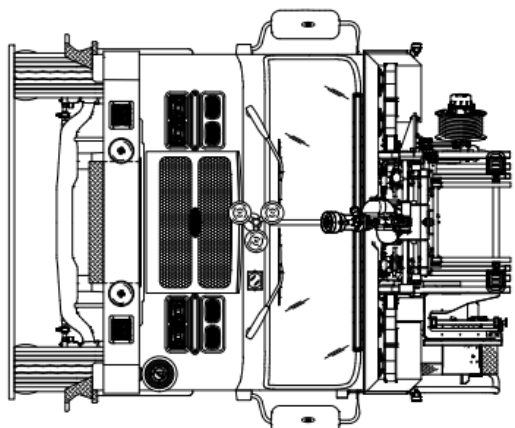

ITEM	QTY	DESCRIPTION	REV	DATE
1	1	ASSEMBLY		
2	1	ASSEMBLY		
3	1	ASSEMBLY		
4	1	ASSEMBLY		
5	1	ASSEMBLY		
6	1	ASSEMBLY		
7	1	ASSEMBLY		
8	1	ASSEMBLY		
9	1	ASSEMBLY		
10	1	ASSEMBLY		
11	1	ASSEMBLY		
12	1	ASSEMBLY		
13	1	ASSEMBLY		
14	1	ASSEMBLY		
15	1	ASSEMBLY		
16	1	ASSEMBLY		
17	1	ASSEMBLY		
18	1	ASSEMBLY		
19	1	ASSEMBLY		
20	1	ASSEMBLY		
21	1	ASSEMBLY		
22	1	ASSEMBLY		
23	1	ASSEMBLY		
24	1	ASSEMBLY		
25	1	ASSEMBLY		
26	1	ASSEMBLY		
27	1	ASSEMBLY		
28	1	ASSEMBLY		
29	1	ASSEMBLY		
30	1	ASSEMBLY		
31	1	ASSEMBLY		
32	1	ASSEMBLY		
33	1	ASSEMBLY		
34	1	ASSEMBLY		
35	1	ASSEMBLY		
36	1	ASSEMBLY		
37	1	ASSEMBLY		
38	1	ASSEMBLY		
39	1	ASSEMBLY		
40	1	ASSEMBLY		
41	1	ASSEMBLY		
42	1	ASSEMBLY		
43	1	ASSEMBLY		
44	1	ASSEMBLY		
45	1	ASSEMBLY		
46	1	ASSEMBLY		
47	1	ASSEMBLY		
48	1	ASSEMBLY		
49	1	ASSEMBLY		
50	1	ASSEMBLY		
51	1	ASSEMBLY		
52	1	ASSEMBLY		
53	1	ASSEMBLY		
54	1	ASSEMBLY		
55	1	ASSEMBLY		
56	1	ASSEMBLY		
57	1	ASSEMBLY		
58	1	ASSEMBLY		
59	1	ASSEMBLY		
60	1	ASSEMBLY		
61	1	ASSEMBLY		
62	1	ASSEMBLY		
63	1	ASSEMBLY		
64	1	ASSEMBLY		
65	1	ASSEMBLY		
66	1	ASSEMBLY		
67	1	ASSEMBLY		
68	1	ASSEMBLY		
69	1	ASSEMBLY		
70	1	ASSEMBLY		
71	1	ASSEMBLY		
72	1	ASSEMBLY		
73	1	ASSEMBLY		
74	1	ASSEMBLY		
75	1	ASSEMBLY		
76	1	ASSEMBLY		
77	1	ASSEMBLY		
78	1	ASSEMBLY		
79	1	ASSEMBLY		
80	1	ASSEMBLY		
81	1	ASSEMBLY		
82	1	ASSEMBLY		
83	1	ASSEMBLY		
84	1	ASSEMBLY		
85	1	ASSEMBLY		
86	1	ASSEMBLY		
87	1	ASSEMBLY		
88	1	ASSEMBLY		
89	1	ASSEMBLY		
90	1	ASSEMBLY		
91	1	ASSEMBLY		
92	1	ASSEMBLY		
93	1	ASSEMBLY		
94	1	ASSEMBLY		
95	1	ASSEMBLY		
96	1	ASSEMBLY		
97	1	ASSEMBLY		
98	1	ASSEMBLY		
99	1	ASSEMBLY		
100	1	ASSEMBLY		