



# JERSEY CITY, NJ

## TRACTOR DRAWN AERIAL

Truck # 147962



### CHASSIS

- Typhoon 58" extruded aluminum cab with severe duty interior
- Cummins X12 525 HP engine with Jacobs compression brake and Allison EVS4500P transmission
- USSC Valor seating for (6) w/ IMMI SmartDock Gen2 SCBA brackets
- Meritor FL-943 21,000 lb front axle
- Meritor RS-30-185 31,000 lb rear axle with Hendrickson FIREMAAX EX air ride suspension
- Meritor MFS-20 23,000 lb tillerman steer axle with Ridewell suspension
- 75,000 lbs. GVWR
- 151" chassis wheelbase with galvanized powder coated frame rails, 343" trailer wheelbase
- 10'-11" +/-2" travel height
- 60'-0" +/-1" overall length

e-one.com

### BODY FEATURES

- Formed aluminum body
- Hose storage driver compartment top, transverse compartments above and below frame, enclosed wheel well storage for (4) SCBA bottles
- Center mounted tunnel with 207' of ground ladders

### ELECTRIC & WARNING

- Weldon V-MUX Multiplex electrical system, Safety Vision® rear camera
- Vehicle data recorder with CrewGuard occupant detection
- (3) Whelen Mini-Freedom IV LED light bars, warning light systems
- Federal Signal PA300 siren
- TecNiq E45 compartment lights, Whelen Pioneer 12V LED front brow light, (2) FireTech 35" 12V LED side brow lights, (2) FireTech 42" 12V LED body scene lights

### AERIAL FEATURES

- 110' vertical reach
- 102' horizontal reach
- Welded extruded aluminum construction
- 2.5 to 1 structural safety factor
- (2) H-type outriggers with 16' spread and short jack capability
- 250 lb. tip load + 75 lbs. equipment (Tip load increases when elevated)
- Advanced Aerial Control System (AACS), (2) FireTech FT-WL-X-9 LED lights at tip, Amdor LED Pathfinder ladder climbing lights and FRC ACT 2-way intercom
- Axe bracket on fly, pike pole brackets on fly, storage brackets w/ 16' roof ladder on base



**E-ONE TILLER**  
**JERSEY CITY NJ**  
*S.O. 147962/QUOTE 128466*  
**TILLER BODY**  
**E-ONE TYPHOON CHASSIS**  
**110 AERIAL LADDER**

THIS DRAWING IS FOR REFERENCE PURPOSES. ALL DIMENSIONS ARE SUBJECT TO MAJOR VARIATIONS DUE TO MANUFACTURING PROCESSES.

This unit is the property of E-One, Inc. and is loaned to you subject to return on demand, unless otherwise agreed to in writing by E-One, Inc. Its contents are confidential and must not be copied or submitted to third parties for use or examination.

COMP.	OPENING	INTERIOR DIMENSION
L1/R1	44.5W 45.5H	35.75W 47.8H 22D
L2/R2	42.5W 55.5H	47.8W 58.8H 24D UPPER TRANS LOWER
L3/R3	42.5W 55.5H	47.8W 58.8H 24D MIDDLE TRANS LOWER
L4/R4	42.5W 55.5H	47.8W 58.8H 24D UPPER TRANS LOWER
L5/R5	42.5W 55.5H	47.8W 58.8H 24D MIDDLE TRANS LOWER
L6/R6	27W 28.25H	31.7W 31H 24D
L7	27W 28.25H	31.7W 31H 12D
R7	27W 28.25H	31.7W 31H 24D

ITEM	LADDER LENGTH	MODRL. NUMBER	QTY
A	50' 3-SECT	TEL-50P	1
B	40' 2-SECT	TEL-40	1
C	35' 2-SECT	FEL-35	1
D	28' 2-SECT	FEL-28	2
E	16' ROOF	DRL-16 (AERIAL BASE)	1
F	16' ROOF	PRL-16	1
G	10' FOLDING	FL-10	1

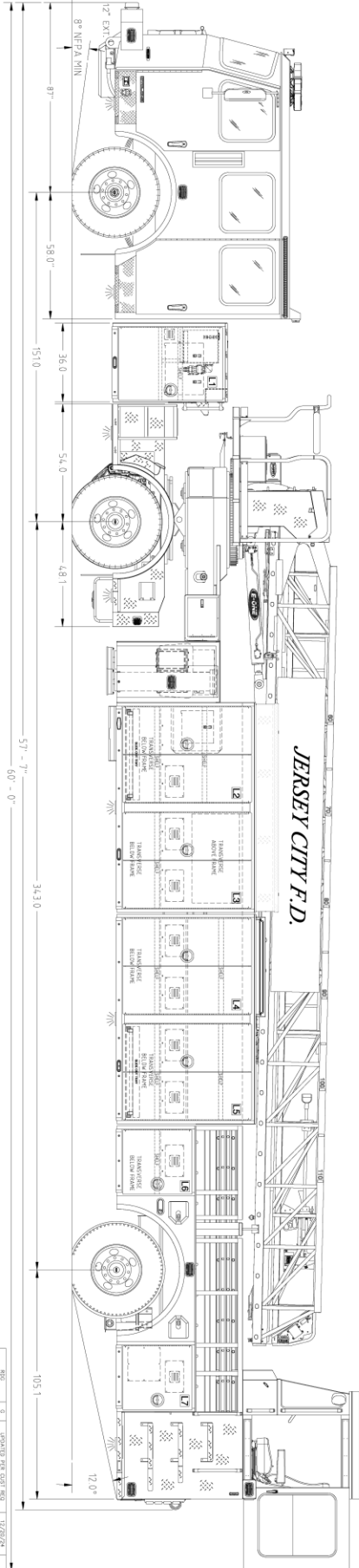
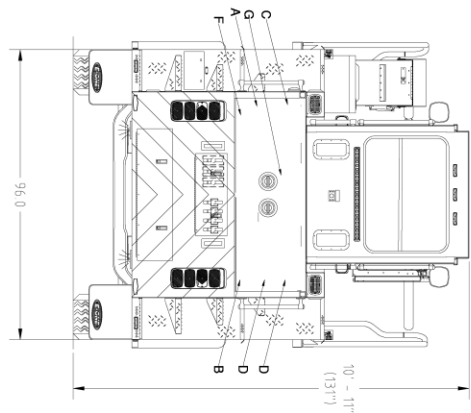

NO.	QTY	DESCRIPTION	DATE
1	1	ASSEMBLY SHEET	10/27/04
2	1	CHASSIS	10/27/04
3	1	OPERATOR'S SEAT	10/27/04
4	1	HYDRAULIC SYSTEM	10/27/04
5	1	WHEELS	10/27/04
6	1	HYDRAULIC PUMP	10/27/04
7	1	HYDRAULIC HOSES	10/27/04
8	1	HYDRAULIC VALVES	10/27/04
9	1	HYDRAULIC CYLINDERS	10/27/04
10	1	HYDRAULIC FITTINGS	10/27/04
11	1	HYDRAULIC PIPING	10/27/04
12	1	HYDRAULIC RESERVOIR	10/27/04
13	1	HYDRAULIC FILTER	10/27/04
14	1	HYDRAULIC HOSE END FITTINGS	10/27/04
15	1	HYDRAULIC HOSE END FITTINGS	10/27/04
16	1	HYDRAULIC HOSE END FITTINGS	10/27/04
17	1	HYDRAULIC HOSE END FITTINGS	10/27/04
18	1	HYDRAULIC HOSE END FITTINGS	10/27/04
19	1	HYDRAULIC HOSE END FITTINGS	10/27/04
20	1	HYDRAULIC HOSE END FITTINGS	10/27/04
21	1	HYDRAULIC HOSE END FITTINGS	10/27/04
22	1	HYDRAULIC HOSE END FITTINGS	10/27/04
23	1	HYDRAULIC HOSE END FITTINGS	10/27/04
24	1	HYDRAULIC HOSE END FITTINGS	10/27/04
25	1	HYDRAULIC HOSE END FITTINGS	10/27/04
26	1	HYDRAULIC HOSE END FITTINGS	10/27/04
27	1	HYDRAULIC HOSE END FITTINGS	10/27/04
28	1	HYDRAULIC HOSE END FITTINGS	10/27/04
29	1	HYDRAULIC HOSE END FITTINGS	10/27/04
30	1	HYDRAULIC HOSE END FITTINGS	10/27/04
31	1	HYDRAULIC HOSE END FITTINGS	10/27/04
32	1	HYDRAULIC HOSE END FITTINGS	10/27/04
33	1	HYDRAULIC HOSE END FITTINGS	10/27/04
34	1	HYDRAULIC HOSE END FITTINGS	10/27/04
35	1	HYDRAULIC HOSE END FITTINGS	10/27/04
36	1	HYDRAULIC HOSE END FITTINGS	10/27/04
37	1	HYDRAULIC HOSE END FITTINGS	10/27/04
38	1	HYDRAULIC HOSE END FITTINGS	10/27/04
39	1	HYDRAULIC HOSE END FITTINGS	10/27/04
40	1	HYDRAULIC HOSE END FITTINGS	10/27/04
41	1	HYDRAULIC HOSE END FITTINGS	10/27/04
42	1	HYDRAULIC HOSE END FITTINGS	10/27/04
43	1	HYDRAULIC HOSE END FITTINGS	10/27/04
44	1	HYDRAULIC HOSE END FITTINGS	10/27/04
45	1	HYDRAULIC HOSE END FITTINGS	10/27/04
46	1	HYDRAULIC HOSE END FITTINGS	10/27/04
47	1	HYDRAULIC HOSE END FITTINGS	10/27/04
48	1	HYDRAULIC HOSE END FITTINGS	10/27/04
49	1	HYDRAULIC HOSE END FITTINGS	10/27/04
50	1	HYDRAULIC HOSE END FITTINGS	10/27/04
51	1	HYDRAULIC HOSE END FITTINGS	10/27/04
52	1	HYDRAULIC HOSE END FITTINGS	10/27/04
53	1	HYDRAULIC HOSE END FITTINGS	10/27/04
54	1	HYDRAULIC HOSE END FITTINGS	10/27/04
55	1	HYDRAULIC HOSE END FITTINGS	10/27/04
56	1	HYDRAULIC HOSE END FITTINGS	10/27/04
57	1	HYDRAULIC HOSE END FITTINGS	10/27/04
58	1	HYDRAULIC HOSE END FITTINGS	10/27/04
59	1	HYDRAULIC HOSE END FITTINGS	10/27/04
60	1	HYDRAULIC HOSE END FITTINGS	10/27/04
61	1	HYDRAULIC HOSE END FITTINGS	10/27/04
62	1	HYDRAULIC HOSE END FITTINGS	10/27/04
63	1	HYDRAULIC HOSE END FITTINGS	10/27/04
64	1	HYDRAULIC HOSE END FITTINGS	10/27/04
65	1	HYDRAULIC HOSE END FITTINGS	10/27/04
66	1	HYDRAULIC HOSE END FITTINGS	10/27/04
67	1	HYDRAULIC HOSE END FITTINGS	10/27/04
68	1	HYDRAULIC HOSE END FITTINGS	10/27/04
69	1	HYDRAULIC HOSE END FITTINGS	10/27/04
70	1	HYDRAULIC HOSE END FITTINGS	10/27/04
71	1	HYDRAULIC HOSE END FITTINGS	10/27/04
72	1	HYDRAULIC HOSE END FITTINGS	10/27/04
73	1	HYDRAULIC HOSE END FITTINGS	10/27/04
74	1	HYDRAULIC HOSE END FITTINGS	10/27/04
75	1	HYDRAULIC HOSE END FITTINGS	10/27/04
76	1	HYDRAULIC HOSE END FITTINGS	10/27/04
77	1	HYDRAULIC HOSE END FITTINGS	10/27/04
78	1	HYDRAULIC HOSE END FITTINGS	10/27/04
79	1	HYDRAULIC HOSE END FITTINGS	10/27/04
80	1	HYDRAULIC HOSE END FITTINGS	10/27/04
81	1	HYDRAULIC HOSE END FITTINGS	10/27/04
82	1	HYDRAULIC HOSE END FITTINGS	10/27/04
83	1	HYDRAULIC HOSE END FITTINGS	10/27/04
84	1	HYDRAULIC HOSE END FITTINGS	10/27/04
85	1	HYDRAULIC HOSE END FITTINGS	10/27/04
86	1	HYDRAULIC HOSE END FITTINGS	10/27/04
87	1	HYDRAULIC HOSE END FITTINGS	10/27/04
88	1	HYDRAULIC HOSE END FITTINGS	10/27/04
89	1	HYDRAULIC HOSE END FITTINGS	10/27/04
90	1	HYDRAULIC HOSE END FITTINGS	10/27/04
91	1	HYDRAULIC HOSE END FITTINGS	10/27/04
92	1	HYDRAULIC HOSE END FITTINGS	10/27/04
93	1	HYDRAULIC HOSE END FITTINGS	10/27/04
94	1	HYDRAULIC HOSE END FITTINGS	10/27/04
95	1	HYDRAULIC HOSE END FITTINGS	10/27/04
96	1	HYDRAULIC HOSE END FITTINGS	10/27/04
97	1	HYDRAULIC HOSE END FITTINGS	10/27/04
98	1	HYDRAULIC HOSE END FITTINGS	10/27/04
99	1	HYDRAULIC HOSE END FITTINGS	10/27/04
100	1	HYDRAULIC HOSE END FITTINGS	10/27/04