

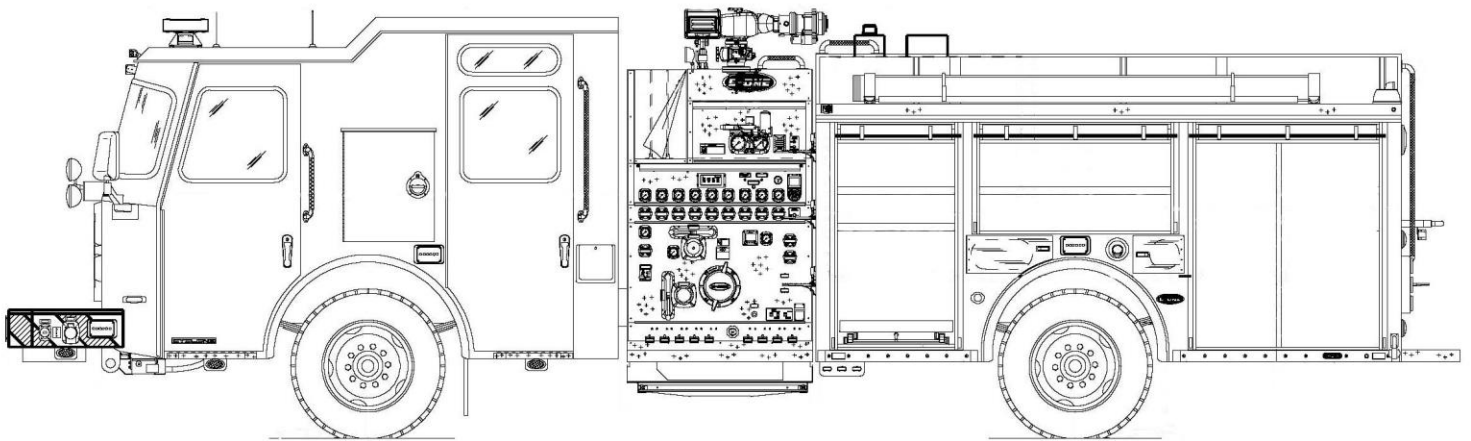

De Pere Fire Rescue, Wisconsin Cyclone® Stainless Steel Pumper

Truck #146213



CHASSIS

- E-ONE Cyclone Long Cab (67.5")
- 4/12 Vista Roof (4" Front, 12" Rear Raise)
- Over-Wheel Medical Compartments
- Cummins L9 450 HP Engine
- Allison EVS 3000P Transmission
- GAWR: Front 20,000#, Rear 27,000#
- Galvanized, Powder Coated and Painted Frame for Corrosion Protection
- Heavy Duty 24" Extended Bumper

BODY FEATURES

- 12 GA 304L Stainless Steel Body
- Full Height Compartments on Each Side of the Body
- Low Hosebed Design
- Enclosed Wheelwell Storage for (7) SCBA Bottles
- Storage Tunnel for Ground Ladders and Pike Poles

ELECTRIC & WARNING

- Whelen Emergency Lighting
- FireTech and Whelen LED Scene Lighting
- FRC inView 360 Camera

PUMP & PLUMBING

- Hale Qmax 1500 GPM Pump
- 750 Gallon Water, 30 Gallon Foam Tanks
- 2-1/2" Driver Side and Officer Side Discharges
- 4" Officer Side Discharge
- 3" Deck Gun Discharge
- Akron 3406 Electric Deck Gun Riser with 3482 Monitor
- 2-1/2" Front Bumper Discharge
- (4) 2-1/2" Rear Discharges
- (2) 1-1/2" and (1) 2-1/2" Crosslays
- FRC PBA500 PumpBoss Pressure Governor



DE PERE FIRE RESCUE
 SO. NO. 148213 (PTSS-CYCN)
 PUMPER 780 GALLON L-TANK
 CYCLONE LONG 4F12R 12" REAR RAISED

		HOSE LOAD	
1500 GPM HALE QMAX PUMP		200'	OF 2-1/2" DJ
750 GALLON WATER TANK		500'	OF 2-1/2" DJ
30 GALLON INTERPRAL™ F.OAM		200'	OF 1-3/4" DJ
		1,050'	OF 5" LDH
		100'	OF 1-3/4" DJ (TOP)
		400'	OF 2-1/2" DJ (BOTTOM)
INTERIOR DIMENSION			
COMP. T.	OPENING	5SH	5SH
L1/R1	31-1/2W	55H	39W
L2/R2	51-1/2W	23-3/4H	50W
L3/R3	48-1/2W	58H	54W
B1	39W	23-3/4H	40W
			35H
			28D

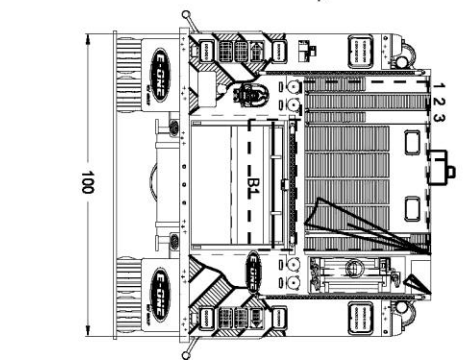
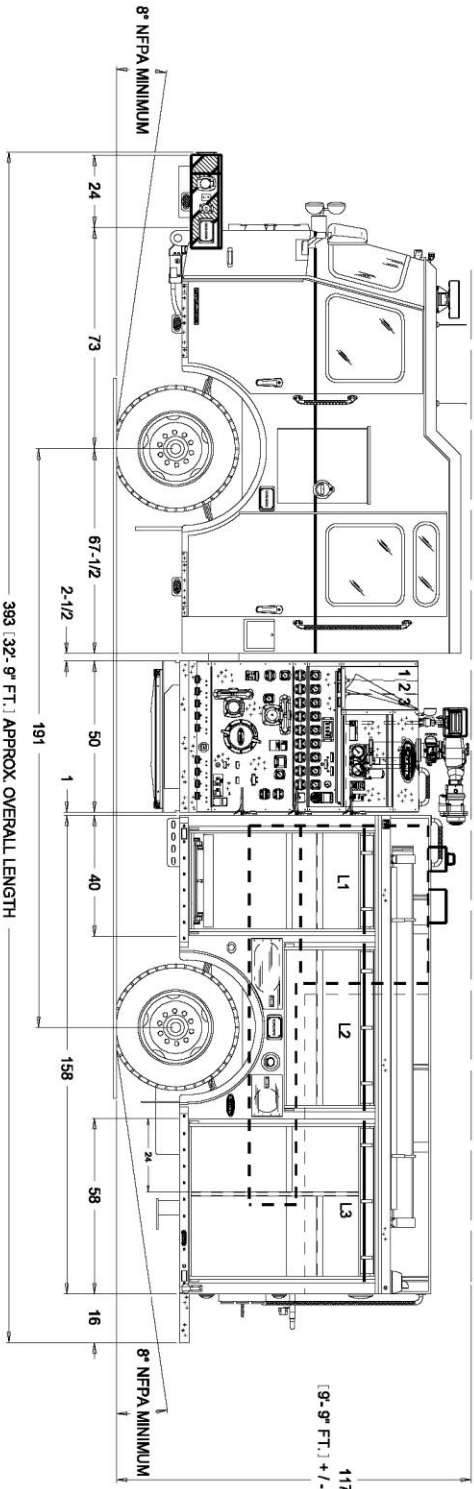
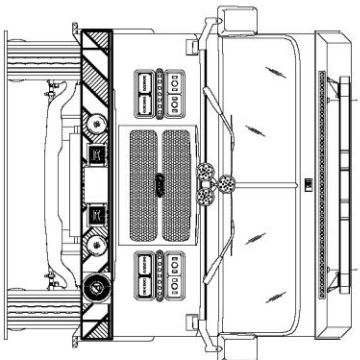
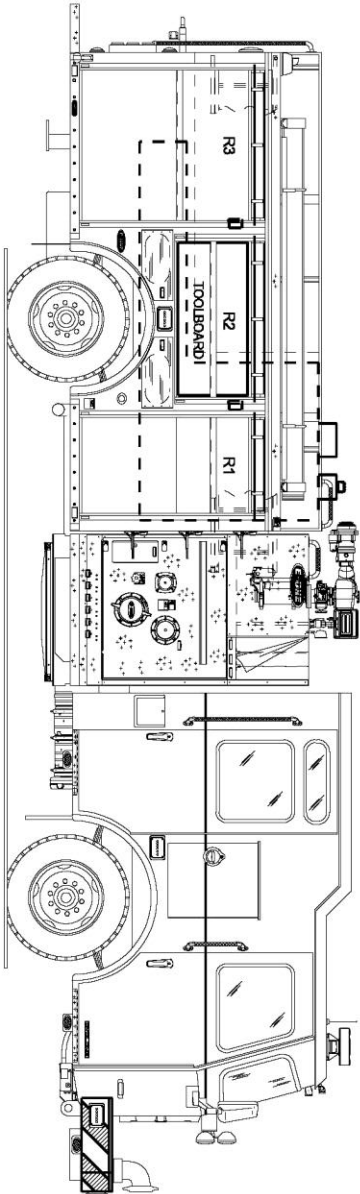

393 [32'-8" FT.] APPROX. OVERALL LENGTH

[9'-9" FT.] +/- 2" APPROX