

FRONT VIEW

COMPARTMENT DIMENSIONS		
COMPT.	CLEAR DOOR OPENING (W x H):	COMPARTMENT INTERIOR (W x H x LD/UD):
L1	39-1/2"W x 55"H	44"W x 30-1/4"H x 27"D L / 44"W x 34-1/4"H x 14"D U
L2	51-1/2"W x 23-3/4"H	60"W x 34-1/4"H x 14"D
L3	39-1/2"W x 55"H	44"W x 30-1/4"H x 27"D L / 44"W x 34-1/4"H x 14"D U
R1	39-1/2"W x 55"H	44"W x 30-1/4"H x 27"D L / 44"W x 34-1/4"H x 14"D U
R2	51-1/2"W x 23-3/4"H	60"W x 34-1/4"H x 14"D
R3	39-1/2"W x 55"H	44"W x 30-1/4"H x 27"D L / 44"W x 34-1/4"H x 14"D U
B1	39"W x 23-3/4"H	46"W x 35"H x 26"D

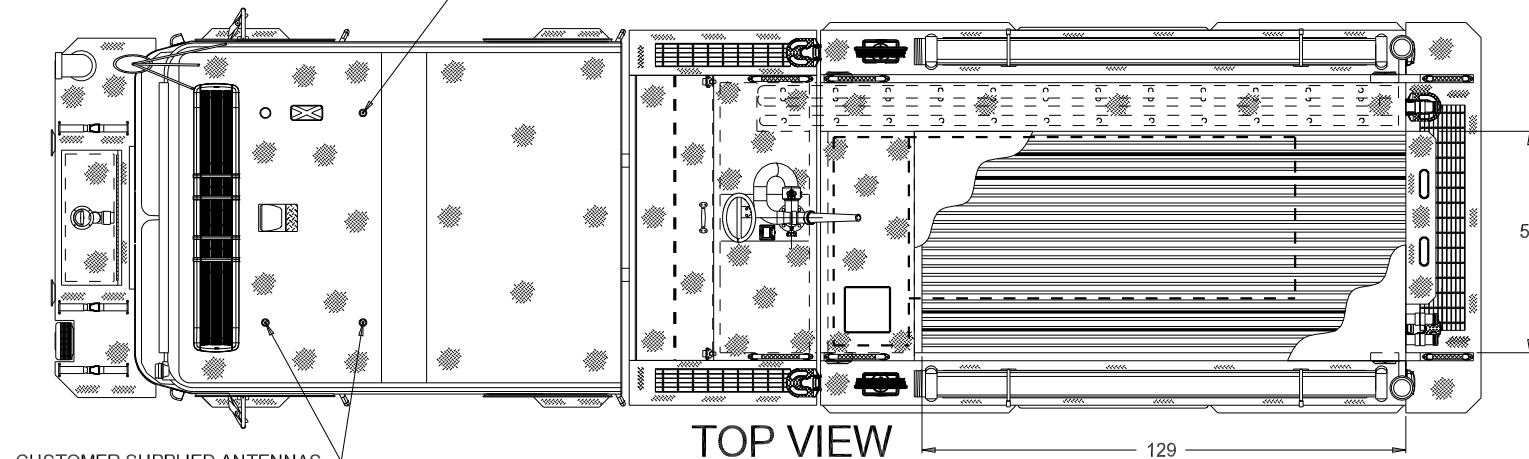

TOP VIEW

HOSE BED LAYOUT:

- BED 1 = 200' OF 2-1/2" HOSE
- BED 2 = 200' OF 1-3/4" HOSE
- BED 3 = 1000' OF 5" LDH HOSE
- BED 4 = 400' OF 2-1/2" HOSE
- BED 5 = 400' OF 2-1/2" HOSE

CROSSLAY #1 = 200' OF 2-1/2" HOSE CROSSLAY #2 = 200' OF 2-1/2" HOSE

HOSE NOT IN QUOTE (SHOWN FOR CLARITY)

PIKE POLES NOT IN QUOTE (SHOWN FOR CLARITY)

HOSE NOT IN QUOTE (SHOWN FOR CLARITY)

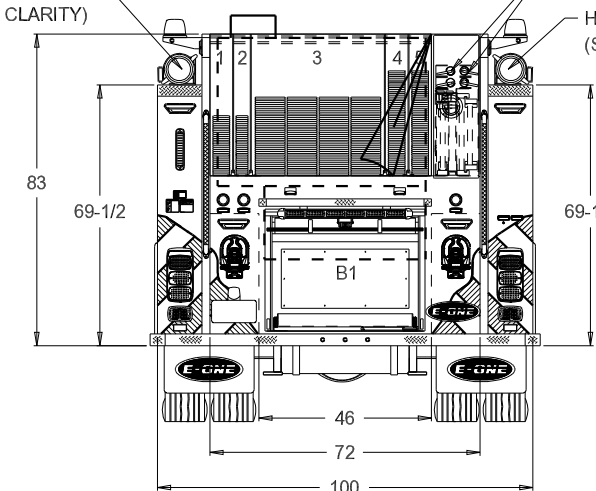

REAR VIEW

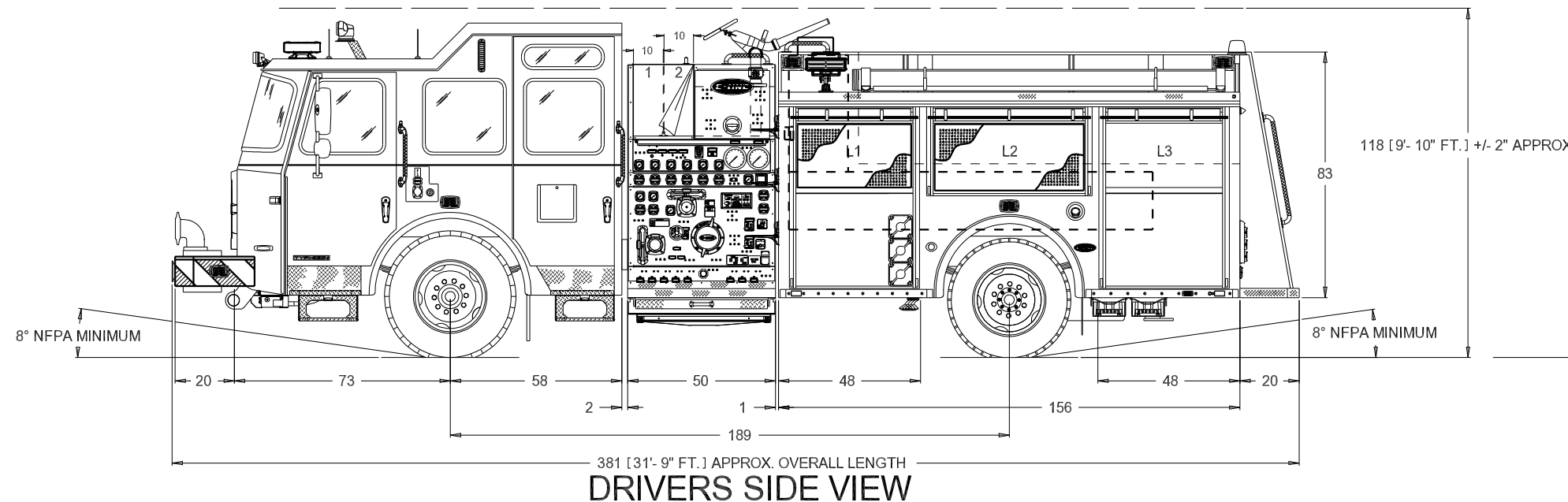

DRIVERS SIDE VIEW

THIS DRAWING IS FOR REFERENCE PURPOSES. ALL DIMENSIONS ARE SUBJECT TO MINOR VARIATIONS DUE TO MANUFACTURING PROCESSES.

This print is the property of E-ONE Inc. and is loaned to you subject to return on demand, unless otherwise agreed to in writing by E-ONE Inc. Its contents are confidential and must not be copied or submitted to third parties for use or examination.

DEALER APPROVAL _____ DATE _____ AS IS
 CUSTOMER APPROVAL _____ DATE _____ WITH REVISIONS

REV.	REVISION NOTE / CO#.	DATE:	DRAWN BY:	Tolerance: Lin: ±.50" Ang: ±50 °	Units: Inches [mm Imports Only]
-	INITIAL DRAWING TO MATCH QUOTE REV. 29	080720	R.S.	Dealer: FIRE SERVICE, INC.	Water Tank Capacity: 550 GALLON L-TANK
A	REVISED TO MATCH QUOTE REV. 62	082520	R.S.	GENERATOR:	Misc:
B	REVISED TO MATCH QUOTE REV. 83	092220	R.S.	Misc:	Misc:
C	REVISED TO MATCH QUOTE REV. 107	110320	R.S.		
D	REVISED TO MATCH QUOTE REV. 169	080221	R.S.		
E	TURNED INTO JOB ORDER (REV Q103996) & ORDER SCRUB Q REV 182	100421	R.H.		
F	REVISED PER PRE-BUILD CR'S QREV 220	010322	R.H.		
G	ADDED ADDITIONAL SO QREV 220	010522	R.H.		
H	UPDATE TO CAB LIGHTBAR	011222	R.H.		
J	UPDATES PER ADDITIONAL CHANGES QREV 223	021422	R.H.		
K	UPDATE TO DISCHARGE HANDLES	022222	R.H.		
L	UPDATES PER ACTION ITEMS & RFP QREV 237	040822	R.H.		
M	UPDATE TO DECK GUN DETAIL	090122	R.H.		



GREEN BAY METRO FIRE DEPT

SO. NO. 145194, 145581 (PTSS-TYPN)

PUMPER 550 GALLON L-TANK

TYPHOON MED. 12" VISTA

FILE NAME: 145194 GREEN BAY METRO FIRE DEPT