



**SOUTH JONES VOLUNTEER FIRE DEPT.**  
**ELLISVILLE, MS**  
*SO.143639 / QUOTE 98727*  
**COMMERCIAL 36 PUMPER**  
**INTERNATIONAL MV607 4DR CAB 4X2 CHASSIS**

1250 GPM HALE QFLO PUMP		HOSE LOAD:	
1000 GALLON WATER		1200' OF 3.00" DJ	
30 GALLON INTEGRAL CLASS "A" FOAM			
COMPT.	OPENING	INTERIOR DIMENSION	
L1	36W 68H	36W 34H 12D	UPPER
L2	56W 34H	36W 30H 26D	LOWER
L3	50W 68H	36W 34H 12D	FRONT UPPER
		36W 30H 26D	FRONT LOWER
		14W 34H 10D	REAR UPPER
R1	36W 30H	36W 30H 26D	FRONT
		36W 30H 26D	REAR
R2	50W 30H	36W 30H 26D	FRONT
B1	36W 41H	36W 30H 26D	UPPER
		36W 30H 26D	LOWER

THIS DRAWING IS FOR REFERENCE PURPOSES. ALL DIMENSIONS ARE SUBJECT TO MINOR VARIATIONS DUE TO MANUFACTURING PROCESSES.

DEALER APPROVAL \_\_\_\_\_ DATE \_\_\_\_\_  AS IS  
 CUSTOMER APPROVAL \_\_\_\_\_ DATE \_\_\_\_\_  WITH REVISIONS

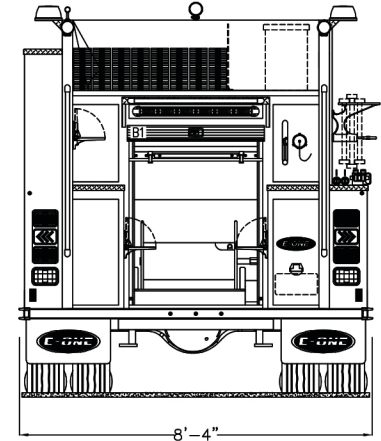
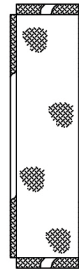

HOSEBED HEIGHT:  
 (FOR REFERENCE ONLY)  
 TO TAILBOARD: 62"  
 TO GROUND: 86"

