



# ORANGE COUNTY FIRE DEPARTMENT ORLANDO, FL.

S.O. 141169-171 / QUOTE 80323  
CUSTOM 42 RESCUE PUMPER  
E-ONE TYPHOON X MEDIUM CAB 4X2 CHASSIS

		HOSE LOAD:	
1250 GPM HALE QFLO PUMP		150'	OF 3.00" DJ
750 GALLON WATER TANK		200'	OF 1.75" DJ
30 GALLON INTEGRAL "A" FOAM CELL		1200'	OF 5.00" LDH
		600'	OF 3.00" DJ

COMPT.	OPENING		INTERIOR DIMENSION			
L1/L3	40W	59H	42W	3H	12D	UPPER
			42W	56H	26D	LOWER
L2	54W	25H	56W	3H	12D	UPPER
			56W	22H	26D	LOWER
R1/R3	40W	59H	42W	25H	12D	UPPER
			42W	30H	26D	LOWER
R2	54W	25H	56W	25H	12D	
B1	36W	47H	38W	47H	26D	

THIS DRAWING IS FOR REFERENCE PURPOSES. ALL DIMENSIONS ARE SUBJECT TO MINOR VARIATIONS DUE TO MANUFACTURING PROCESSES.

**APPROVED FOR PRODUCTION**

DESIGNER: RAY STILL DATE: 2017-APR-13

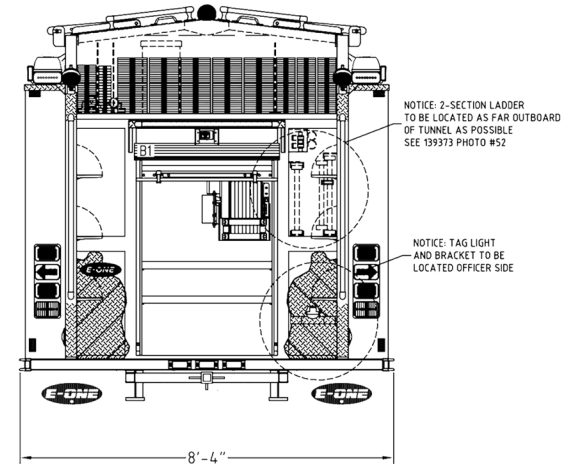

HOSEBED HEIGHT:  
(FOR REFERENCE ONLY)  
TO TAILBOARD: 68"  
TO GROUND: 90"

NOTICE: ADJUSTABLE SHELF TRACK TO EXTEND TO SAME HEIGHT AS BOTTOM OF BREAKER BOX

